

RECOMMENDED P.C.B. LAYOUT

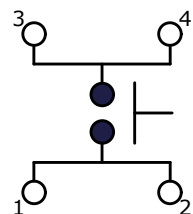

CIRCUIT: SPST

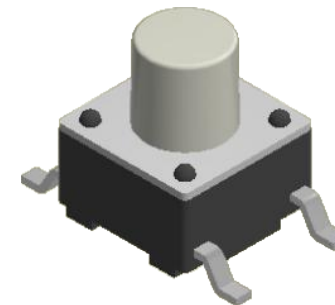
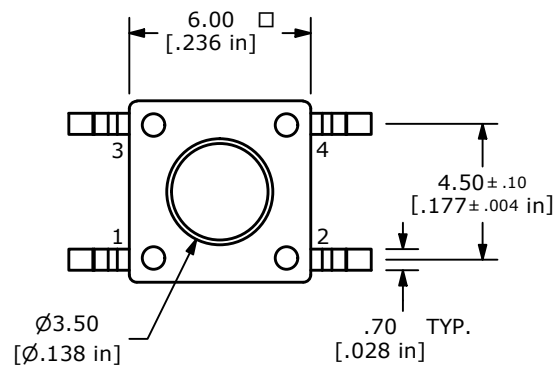
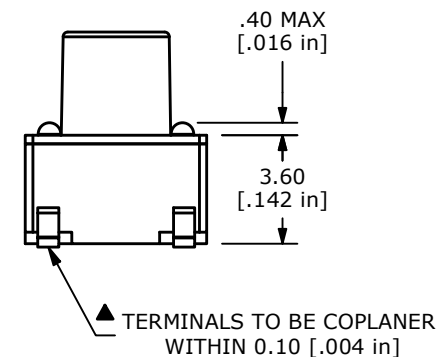
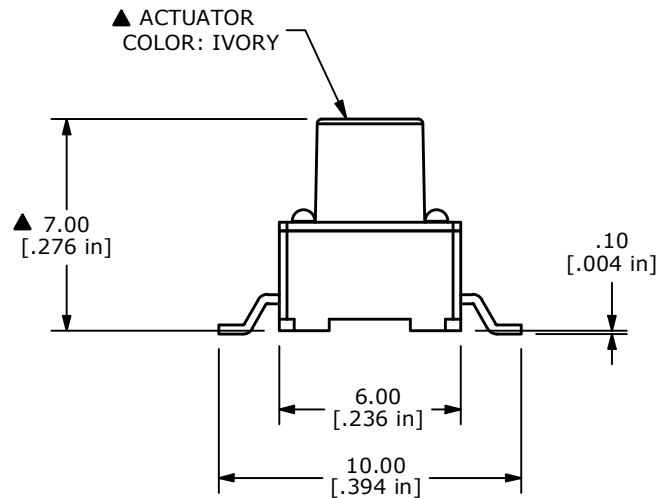

NOTES:

1. ALL DIMENSIONS IN MM
2. GENERAL TOLERANCE: X.X=±0.4
X.XX=±0.25
3. TERM. NUMBERS FOR REFERENCE ONLY.
4. RATING: 50VDC, 50mA
- ▲ 5. OPERATING FORCE: 260 ± 50 gf
6. TRAVEL: 0.25mm +0.2/-0.1mm
7. CONTACT RESISTANCE: 100 MILLI OHMS MAX. (INITIAL)
8. MECHANICAL/ELECTRICAL LIFE 100,000 CYCLES MIN.
- ▲ 9. CONTACT MATERIAL: SILVER
- ▲ 10. PACKAGE: TAPE AND REEL, 650 PIECES PER REEL
11. ▲ DENOTES CRITICAL PARAMETER
12. OPERATING TEMP: -40°C TO 85°C



C	24700	CHANGE OPERATING TEMP	2/4/21	JM
B	14670	REVISED AND REDRAWN	2/4/05	AR
REV	PCR NO	DESCRIPTION	DATE	BY

TITLE TL3301FF260QG				
SCALE	DATE	DR	DWG	REV
4:1	8/1/1997	MM	P010532	C

THE INFORMATION CONTAINED IN THIS DOCUMENT IS PROPRIETARY TO E-SWITCH AND IS NOT TO BE COPIED OR TRANSFERRED